



ANDERSEN MATS WORK ANYWHERE YOU DO

ENTRANCE MATS

AN INTEGRAL COMPONENT OF A GREEN BUILDING

Soil is everywhere. It is a part of the earth we live on and managing it is a vital part of our everyday existence. The U.S. Green Building Council has developed a rating system for new and existing buildings to encourage building owners to earn credit for meeting certain housekeeping criteria. Strategies include the creation and maintenance of entrance systems and mats that prevent particles from entering the building. Recommendations include a minimum of 10-12 feet of quality matting products at entrances. At the heart of an entrance system is prevention of contaminants from entering a building. 85% of all soil enters a building on the feet of people entering the building. Of this, at least 80% is dry soil and the rest is oily. The dry soil can range from large particles to powder-like dust. Over the years, many products have been developed and sold to help keep soil at the door and out of the building. The key to the success of a mat's performance is whether it will do what an entrance mat should do.

HOW SHOULD AN ENTRANCE MAT PERFORM?

In a Green Building an entrance mat is the first line of defense against contaminants and particles entering the building. As such, there are four things an entrance mat should do:

- 1. Stop soil and water.** 85% of all soil enters a building on the feet of the building occupants. High performance mats are more effective at stopping soil from entering buildings.
- 2. Store soil and water for removal at a convenient time.** Storing means that a high performance mat contains soil in a place where it can be removed effectively and safely with minimum impact on the building. A building with minimized contaminants reduces the amount of cleaning chemicals required. This reduces airborne contaminants and volatile organic contaminants (VOCs) from cleaning chemicals, thereby improving a building's Indoor Air Quality (IAQ).
- 3. Minimize tracking of stored soil and water into the building.** A mat with a permanent bi-level construction will store soil and water below shoe level to prevent it from being transferred into the building. This is perhaps the most important thing an entrance mat should do. Mats with a non-reinforced surface will crush flat and once soil is deposited on these mats, it can reattach to the shoe of another person and be tracked further into the building.
- 4. Provide a safe surface for traffic.** Entrance mats should contain contaminants within the structure of the mat and not allow them to seep onto the floor causing a potential slip/fall accident. Mats without a rubber reinforced permanent bi-level construction become saturated with water that can cause a loss of traction on the mat or the floor adjacent to it.





ANDERSEN MATS WORK ANYWHERE YOU DO

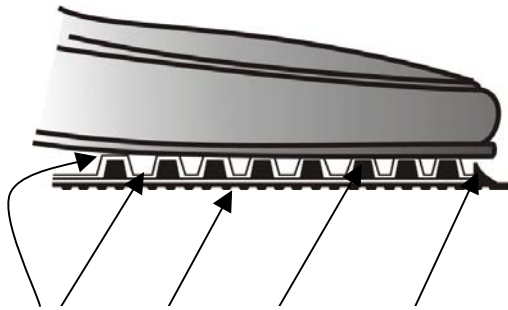

Bi-level Construction Gripper Base Rubber Reinforcement Water Dam

CROSS SECTION OF WATERHOG® MAT CONSTRUCTION

The best performing entrance mats provide a safe, effective, and attractive surface. These are the features of an **Andersen WaterHog®** entrance mat.

1. Soil and moisture control are provided by the permanent rubber reinforced bi-level construction with a durable textile face. Soil and water are scraped off and held by the mat away from foot traffic.
2. Safety is provided by a water dam around the perimeter to prevent water seepage onto the surrounding floor thereby protecting against slip/fall accidents
3. **WaterHog®** mats are the toughest, most attractive mats available. With a variety of product types and an extensive array of sizes and colors, they are an integral part of a green building entrance.

A minimum of 10 – 12 feet of entrance mats provide the most effective soil management

HOW MUCH IS ENOUGH?

85% of the soil brought into any building can be contained within the first 10 to 12 feet.

DISPOSAL CONCERNS

The most important part of the Green Building program is concern for the environment including the use of products that can help reduce the need for landfills. The key issue with mats is a mat's performance life. High performance mats made with a permanent bi-level construction can have a performance life of many years. Mats without a rubber reinforced permanent bi-level construction have a 90 – 180 day performance life. To function effectively in a green building, these low-performance mats will need to be replaced more frequently causing a disposal issue.